

**MECHANICAL DATA**

Dimensions in mm (inches)

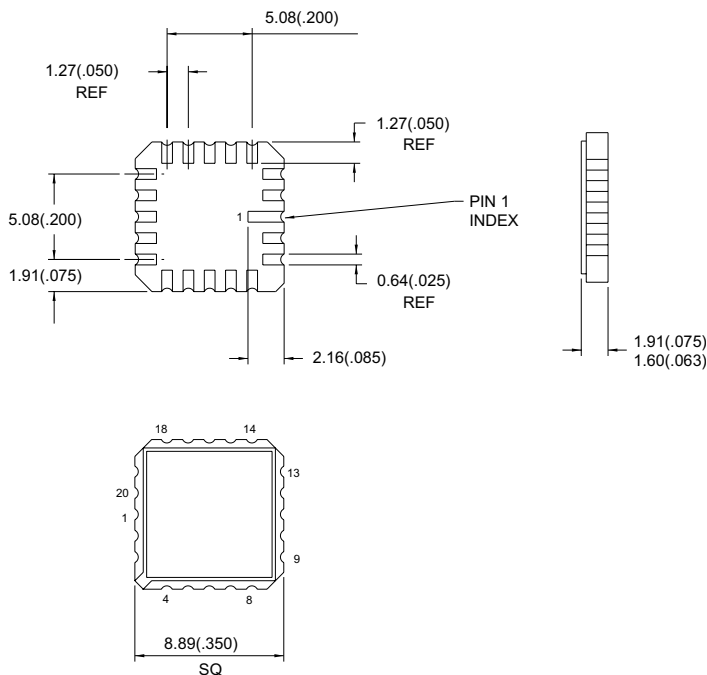

**SURFACE MOUNT  
QUAD PNP TRANSISTOR**

**FEATURES**

- FOUR INDEPENDENT TRANSISTORS IN A 0.35 INCH SQUARE CERAMIC PACKAGE
- SURFACE MOUNTABLE
- HERMETICALLY SEALED PACKAGE
- SCREENING OPTIONS AVAILABLE

**DESCRIPTION**

The 2N2907AQ-LCC20 is a 20 pad, hermetically sealed, Ceramic Surface Mount Transistor array, consisting of four 2N2907A silicon PNP transistor die.

**PACKAGE LCC20**

Pin 1 = n/c	Pin 6 = n/c	Pin 11 = n/c	Pin 16 = n/c
Pin 2 = Collector 1	Pin 7 = Emitter 2	Pin 12 = Collector 3	Pin 17 = Emitter 4
Pin 3 = n/c	Pin 8 = Base 2	Pin 13 = n/c	Pin 18 = Base 4
Pin 4 = Base 1	Pin 9 = n/c	Pin 14 = Base 3	Pin 19 = n/c
Pin 5 = Emitter 1	Pin 10 = Collector 2	Pin 15 = Emitter 3	Pin 20 = Collector 4

**ABSOLUTE MAXIMUM RATINGS** ( $T_A = 25^\circ\text{C}$  unless otherwise stated)

$V_{CBO}$	Collector – Base Voltage	60V
$V_{CEO}$	Collector – Emitter Voltage	60V
$V_{EBO}$	Emitter – Base Voltage	5V
$I_C$	Collector Current	600mA
$I_V$	Isolation Voltage	500V <sub>DC</sub>
$P_D$	Total Device Dissipation @ $T_A = 25^\circ\text{C}$ (four devices driven equally)	1W
$P_D$	Total Device Dissipation @ $T_S^{(1)} = 25^\circ\text{C}$ (four devices driven equally)	2W <sup>(2)</sup>
$T_J, T_{STG}$	Operating and Storage Junction Temperature Range	-65 to +200°C
	Soldering Temperature (vapor phase reflow for 30 sec)	215°C
	Soldering Temperature (heated collect for 5 sec)	260°C

**ELECTRICAL CHARACTERISTICS** ( $T_A = 25^\circ\text{C}$  unless otherwise stated)

Parameter	Test Conditions	Min.	Typ.	Max.	Unit	
<b>OFF CHARACTERISTICS</b>						
$V_{(BR)CEO}$	Collector – Emitter Sustaining Voltage	$I_C = 10\text{mA}$	$I_B = 0$	60	V	
$V_{(BR)CBO}$	Collector – Base Breakdown Voltage	$I_C = 10\mu\text{A}$	$I_E = 0$	60	V	
$V_{(BR)EBO}$	Emitter – Base Breakdown Voltage	$I_E = 10\mu\text{A}$	$I_C = 0$	5	V	
$I_{CBO}$	Collector – Base Cut-off Current	$I_E = 0$	$V_{CB} = 50\text{V}$		10	nA
			$T_A = 150^\circ\text{C}$		10	$\mu\text{A}$
$I_{EBO}$	Emitter Base Cut-off Current	$I_C = 0$	$V_{EB} = 3.5\text{V}$		50	nA
<b>ON CHARACTERISTICS</b>						
$V_{CE(sat)}$	Collector – Emitter Saturation Voltage	$I_C = 150\text{mA}$	$I_B = 15\text{mA}^{(3)}$		0.4	V
		$I_C = 500\text{mA}$	$I_B = 50\text{mA}^{(3)}$		1.60	
$V_{BE(sat)}$	Base – Emitter Saturation Voltage	$I_C = 150\text{mA}$	$I_B = 15\text{mA}^{(3)}$		1.3	V
		$I_C = 500\text{mA}$	$I_C = 50\text{mA}^{(3)}$		2.6	
$h_{FE}$	Forwarded Current Transfer Ratio	$I_C = 0.1\text{mA}$	$V_{CE} = 10\text{V}$	75		—
		$I_C = 1\text{mA}$	$V_{CE} = 10\text{V}$	100	450	
		$I_C = 10\text{mA}$	$V_{CE} = 10\text{V}$	100		
		$I_C = 150\text{mA}^{(3)}$	$V_{CE} = 10\text{V}$	100	300	
		$I_C = 500\text{mA}^{(3)}$	$V_{CE} = 10\text{V}$	50		
		$I_C = 10\text{mA}$	$V_{CE} = 10\text{V}$	50		
			$T_A = -55^\circ\text{C}$			
<b>SMALL SIGNAL CHARACTERISTICS</b>						
$h_{fe}$	Forward Current Transfer Ratio	$I_C = 1\text{mA}$	$V_{CE} = 10\text{V}$	$f = 1\text{kHz}$	100	—
$h_{fe}$	Forward Current Transfer Ratio	$I_C = 50\text{mA}$	$V_{CE} = 20\text{V}$	$f = 100\text{MHz}$	2	
$C_{obo}$	Open Circuit Output Capacitance	$V_{CB} = 10\text{V}$	$100\text{kHz} \leq f \leq 1\text{MHz}$		8	pF
$C_{ibo}$	Input Capacitance(output open)	$V_{EB} = 2\text{V}$	$100\text{kHz} \leq f \leq 1\text{MHz}$		30	
<b>SWITCHING CHARACTERISTICS</b>						
$t_{on}$	Turn-On Time	$V_{CC} = 30\text{V}$	$I_C = 150\text{mA}$	$I_{B1} = 15\text{mA}$	45	ns
$t_{off}$	Turn-Off Time	$V_{CC} = 30\text{V}$	$I_C = 150\text{mA}$	$I_{B1} = I_{B1} = 15\text{mA}$	300	

**NOTES:**

- 1)  $T_s$  = Substrate Temperature that the chip carrier is mounted on.
- 2) Derate Linearly  $11.4\text{mW}/^\circ\text{C}$  above  $25^\circ\text{C}$ . This rating is provided as an aid to designers. It is dependent upon mounting material and methods and is not measureable as an outgoing test.
- 3) Pulse Test Pulse Wide  $\leq 300\mu\text{s}$  , Duty Cycle  $\leq 2\%$